



Cinderella[®]
Cinderella Eco Group

SETTING THE STANDARD

Cinderella Eco Group, a family-owned company from Midsund, Norway, has pioneered water-free incineration toilets for more than 25 years. As part of the historic Sjøvik Group, we design and manufacture sustainable sanitation solutions for diverse global markets, setting the standard in quality and innovation.



Good health and well-being
Also at the workplace



THE MODERN WORKPLACE:

WATER FREE INCINERATION TOILETS FOR TRUCK CABINS

The vision of a modern workplace extends beyond mere functionality; it embraces the creation of dignified working conditions that prioritize the well-being of employees. This principle is crucial not only in traditional office settings but also in the transport industry, where the demands of long hours on the road can significantly impact driver comfort and health. Recognizing that every detail, including often-overlooked aspects like restroom facilities, contributes to a safe and productive work environment is essential.

Cinderella's innovative incineration toilet solutions offer a practical and hygienic answer to these challenges, enabling drivers to perform their duties effectively while enjoying amenities that reflect a

commitment to their dignity and well-being. By integrating our technology into truck cabins, we ensure that drivers have access to a reliable and practical toilet, even in the most remote locations.

This solution not only enhance daily operations by improving convenience and safety but also contribute to creating a gender-neutral and appealing workplace. In an era where modern standards are expected across all industries, we all share a responsibility to strive toward achieving the UN sustainability goals.

Cinderella Eco Group is proud to contribute to the potential of setting new standards in the transport sector.

FEATURES

NEW! INNOVATIVE PRODUCT

The world's first diesel-powered incineration toilet

CERTIFIED

Designed with the highest quality materials to meet the highest standards and operational reliability.

PRACTICAL LIFTING MECHANISM

Lifts the outer shell in a simple motion.

NO TANKS NEEDED

Waste is safely incinerated in the unit itself. Easy access to ash tray for emptying.

HIGH CAPACITY

3-4 visits per hour

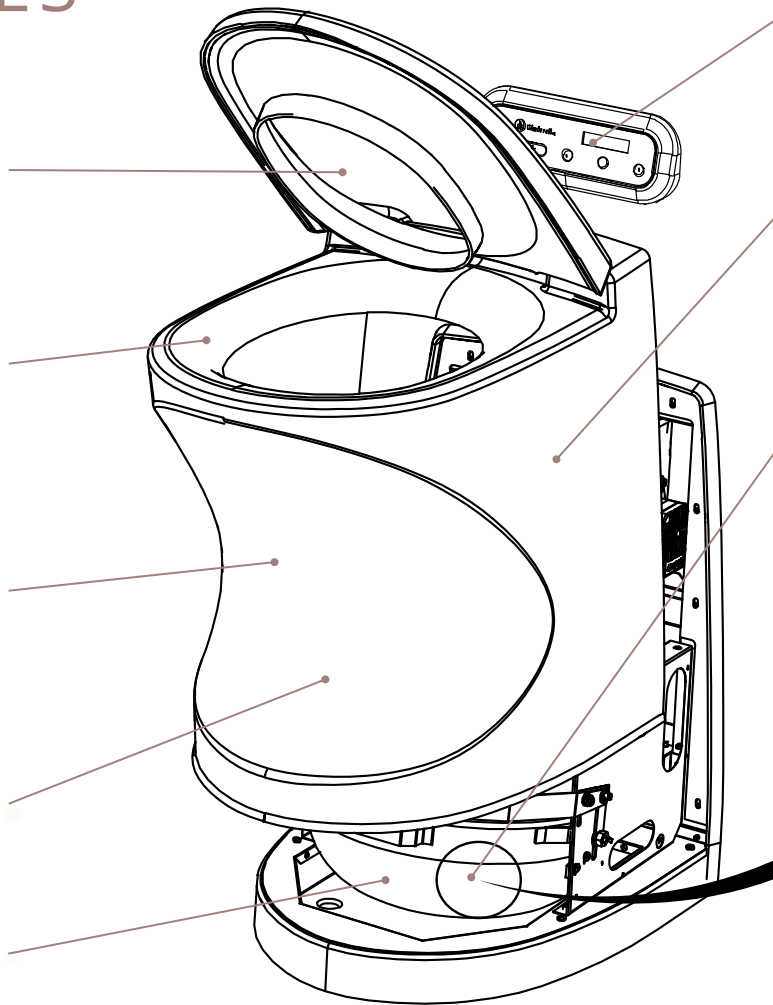

CONTROL PANEL
Informative display with toilet status and operational messages

INTEGRATED SAFETY

Equipped with electro-mechanical sensors and flameguard. The toilet is engineered to ensure safe and reliable operation at all times.

HYGIENIC SOLUTION

Maintains very high hygiene standards, is odor-free, and leaves only clean ash



Scan the QR code to see a useful video on how to use the Cinderella toilet.

SPECIFICATIONS

MEASUREMENT AND TECHNICAL SPECIFICATIONS	
Height	540 mm
Seated height	490 mm
Width	390 mm
Depth	590
Weight	20 kg
Capacity	3-4 visits per hour
Standby Power Consumption	0.005 Amp
Peak load	10.0 Amp
Power consumption (incineration)	1.4 Amp
Diesel consumption	150 - 250 ml per incineration
Exhaust fan	12V DC
Fuel	Automotive quality diesel
Electrical power supply	12V DC / 10 Amp (11-14.4V)
Maximum burner effect	2.1 kWh