



KING KING CANADA



2" GASOLINE WATER PUMP



Read this manual. Do not attempt to operate this water pump until you have read and understood the safety, operation, and maintenance instructions

MODEL: KCG-2WPG

INSTRUCTION MANUAL

COPYRIGHT © 2019 ALL RIGHTS RESERVED BY KING CANADA TOOLS INC.

WARRANTY & SERVICE INFORMATION

**1-YEAR
LIMITED WARRANTY
FOR THIS 2" GASOLINE WATER PUMP**

**KING CANADA TOOLS
OFFERS A 1-YEAR LIMITED WARRANTY
FOR NON-COMMERCIAL USE.**



**IF YOU ARE EXPERIENCING PROBLEMS,
BEFORE RETURNING TO THE RETAILER,
CALL THIS TOLL-FREE NUMBER
FOR SERVICE INFORMATION**

1-877-636-4214

BEFORE CALLING THE ABOVE TOLL-FREE NUMBER, PLEASE READ THIS MANUAL, SPECIFICALLY THE SAFETY PRECAUTIONS, THE INSPECTION BEFORE OPERATION AND THE TROUBLESHOOTING GUIDE.

• DO NOT RETURN THE DEFECTIVE PRODUCT TO THE RETAILER.

WARRANTY INFORMATION

PROOF OF PURCHASE

Please keep your dated proof of purchase for warranty and servicing purposes.

REPLACEMENT PARTS

Replacement parts for this water pump are available at our authorized KING CANADA water pump service centers across Canada. For servicing, call the above toll free number to get servicing instructions and be sure to have your proof of purchase if you are claiming warranty work.

LIMITED TOOL WARRANTY

KING CANADA makes every effort to ensure that this product meets high quality and durability standards. KING CANADA warrants to the original retail consumer a 1-year limited warranty as of the date the product was purchased at retail and that each product is free from defects in materials.

THIS WARRANTY IS NOT TRANSFERABLE AND DOES NOT COVER

- Damage or liability caused by shipping, improper handling, improper installation, improper maintenance, improper modification, or the use of accessories and/or attachments not specifically recommended.
- Repairs necessary because of operator abuse or negligence, or the failure to install, operate, maintain, and store the product according to the instructions in the owner's manual.
- Damage caused by cold, heat, rain, excessive humidity, corrosive environments and materials, or other contaminants.
- Expendable items that become worn during normal use such as fuel filters, air cleaners, spark plugs, and engine oil.
- Cosmetic defects that do not interfere with product functionality.
- Freight costs from customer to an authorized warranty service location.
- Repair and transportation costs of products or parts determined not to be defective.
- ANY INCIDENTAL, INDIRECT OR CONSEQUENTIAL LOSS, DAMAGE, OR EXPENSE THAT MAY RESULT FROM ANY DEFECT, FAILURE OR MALFUNCTION OF THE PRODUCT.

• RETAIN THE ORIGINAL CASH REGISTER SALES RECEIPT AS PROOF OF PURCHASE FOR WARRANTY WORK.

KING CANADA shall in no event be liable for death, injuries to persons or property or for incidental, special or consequential damages arising from the use of our products. Shipping and handling charges may apply. If a defect is found, KING CANADA will either repair or replace the product.

BASIC & SPECIFIC SAFETY RULES

BASIC SAFETY WARNINGS

BE CAREFUL!

**DO NOT USE IN YOUR HOUSE
KEEP FLAMMABLE MATERIALS AWAY**

WHEN REFUELING:

**STOP ENGINE!
NO SMOKING!
DO NOT SPILL GASOLINE!**

EXHAUST FUMES ARE DANGEROUS

•Never operate the engine in a closed area or it may cause unconsciousness and death within a short time. Operate in a well ventilated area.

FUEL IS HIGHLY FLAMMABLE AND POISONOUS

•Always turn off the engine when refueling.
•Never refuel while smoking or in the vicinity of an open flame.
•When operating or transporting this water pump, be sure to keep it upright. If it tilts, fuel may leak from the carburetor or fuel tank.

ENGINE AND MUFFLER MAY BE HOT

WARNING! The engine muffler will be very hot after use, avoid touching the engine or muffler while they are still hot.

•Place the water pump in an appropriate location, away from children and pedestrians.
•Avoid placing any flammable materials near the exhaust outlet during operation.
•Keep a 4ft. clearance from buildings or other equipment around the water pump to prevent overheating.

FUEL

Make sure there is sufficient fuel in the tank.

ATTEMPTING TO FILL THE FUEL TANK WHILE THE ENGINE IS RUNNING.

Gasoline and gasoline vapors can become ignited by coming in contact with hot components such as the muffler, engine exhaust gases, or from an electrical spark.

Turn engine off and allow it to cool before adding fuel to the tank. Equip area of operation with a fire extinguisher certified to handle gasoline or fuel fires.

SPARKS, FIRE, HOT OBJECTS

Cigarettes, sparks, fires, or other hot objects can cause gasoline or gasoline vapors to ignite. Add fuel to tank in well ventilated area. Make sure there are no sources of ignition near the water pump.

INADEQUATE VENTILATION FOR WATER PUMP

Materials placed against or near the water pump or operating the water pump in areas where the temperature exceeds 40° C ambient (such as storage rooms or garages) can interfere with its proper ventilation features causing overheating and possible ignition of the materials or buildings.

Operate water pump in a clean, dry, well ventilated area a minimum of four feet from any building, object or wall. **DO NOT OPERATE UNIT INDOORS OR IN ANY CONFINED AREA.**

RISK OF BREATHING - INHALATION HAZARD

Operate water pump in clean, dry, well ventilated area. Never operate unit in enclosed areas such as garages, basements, storage, sheds, or in any location occupied by humans or animals.

Keep children, pets and others away from area of operating unit. Breathing exhaust fumes will cause serious injury or death. **Gasoline engines produce toxic carbon monoxide exhaust fumes.**

SPECIFIC OPERATIONAL WARNINGS

PRIMING WATER PUMP BEFORE STARTING ENGINE

•**WARNING! NEVER TURN THE ENGINE ON UNTIL YOU HAVE PRIMED THE WATER PUMP.** This means you can not start the engine until the hoses and fittings are assembled as described in this manual and then adding water up to the rim of the priming cap and tightening priming cap. If this warning is not followed, you will void your warranty and cause severe damage to the machine seal which will then need to be replaced.

STRAINER BASKET

• If this water pump is used to pump water from a river, it is very important to install the strainer basket to the inlet hose. The strainer basket must be kept below the surface of the water to avoid air suction and at a certain distance from the river bottom or river bank to prevent suction of rocks, weeds.

AVOID AIR SUCTION!

• It is very important to never allow air suction, the water pump inlet hose must be submerged in water at all times or else you risk damaging your water pump.

WINTER USE

• If this water pump is used in winter, as soon as you are finished and stop the engine, it is very important to drain all the water from the pump to prevent internal freezing. Undo drain cap at the bottom of the water pump to drain water out.

GETTING TO KNOW YOUR WATER PUMP

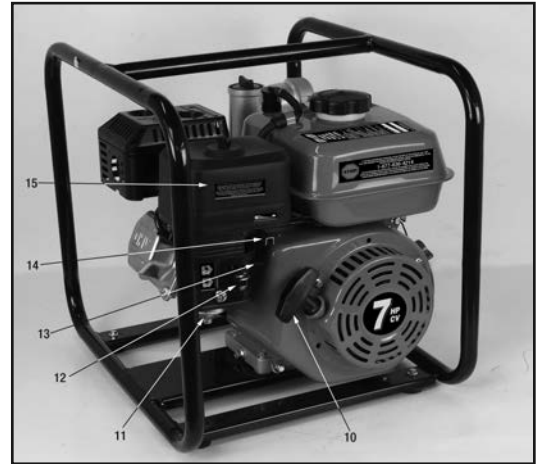
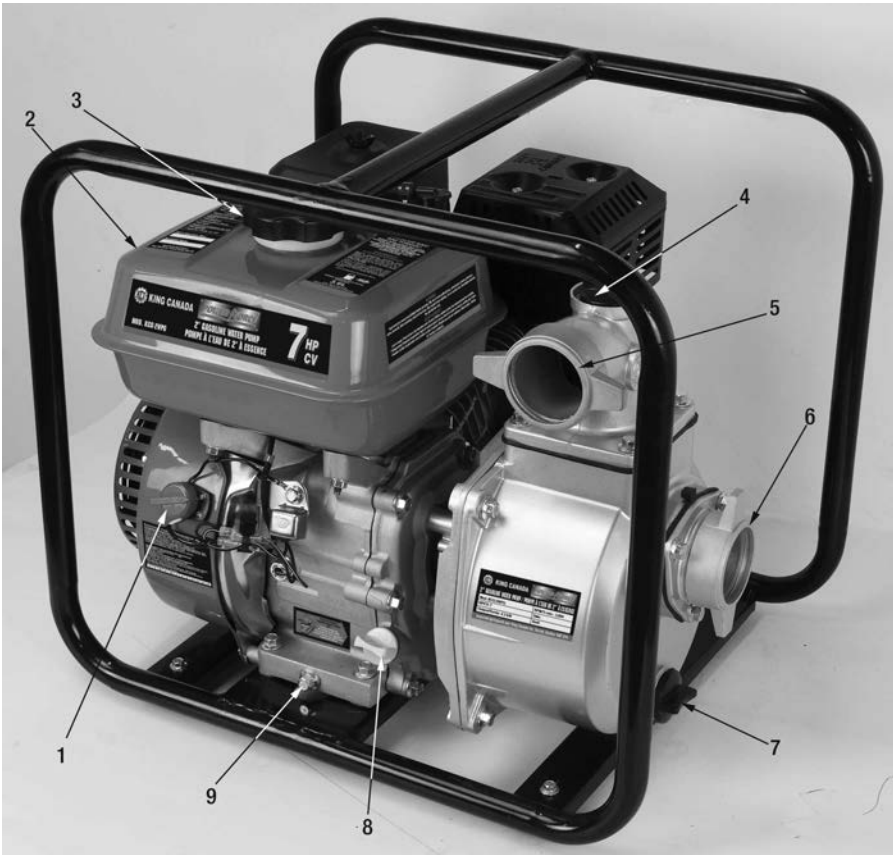

1. **Power ON switch.** This switch must be switched to "ON" before pulling recoil starter.
2. **Fuel tank.** Unleaded gasoline only! 3.6 Liter capacity.
3. **Fuel cap.** Make sure the fuel cap is always screwed on tightly.
4. **Priming cap.** Warning! Never turn the engine on until you have primed the water pump. This means adding water up to the rim of the priming cap and tightening priming cap.
5. **Water pump outlet.**
6. **Water pump inlet.**
7. **Water pump drain cap.** Before storage, drain all water from the water pump by removing this cap.
8. **Oil gauge dipstick.** Check the oil level using this oil gauge dipstick.
9. **Oil drain bolt.** Remove this drain bolt to drain oil.
10. **Recoil starter.** Starts the engine.
11. **Carburetor.**
12. **Fuel Shut-off Valve Lever.** Regulates the flow of fuel to the engine. The fuel shut-off lever must be positioned completely to the right before starting the engine.
13. **Choke lever.** Once the engine is started, it is necessary to gradually move the choke lever to the left, see instructions further in this manual.
14. **Throttle lever.** Regulates the speed of the engine, it is recommended to move the throttle lever completely to the right to obtain maximum results.
15. **Air cleaner element/cover.** Periodically the air cleaner filter must be checked and maintained, see maintenance section.
16. **Muffler.** Warning! Muffler gets hot. Avoid placing any flammable materials near the exhaust outlet during operation.
17. **Spark plug/cover.** The spark plug must be checked periodically for carbon deposits and/or discoloration, see maintenance section.

MODEL	KCG-2WPG
Inlet/Outlet Diameter	2" NPT
Maximum Pump Capacity	466 L/min. (123 GPM)
Total Head Lift	105 ft.
Suction Head Lift	24.6 ft.
Engine (OHV)	7 HP
Engine speed	3,600 RPM
Displacement (cc)	208
Fuel	Unleaded Gasoline
Fuel tank (L)	3.6
Oil capacity (L)	0.6
Starting System	Recoil
Dimensions (LxWxH)	19" x 15" x 17"
Weight	50 lbs.

INSPECTION & SET-UP BEFORE STARTING ENGINE

WARNING! To prevent permanent damage to your water pump, you **MUST** check oil level, fuel level, air cleaner filter, assemble all hoses (not supplied), hose adaptors and strainer basket, prime the water pump and have the inlet hose submerged in water before starting water pump engine.

OIL LEVEL

WARNING! This water pump has been shipped from the factory without oil or very little oil in the crankcase. Operating the unit without the correct amount of oil can damage the engine. Oil crankcase capacity: 0.6 litres.

Always check the oil level before starting the water pump, make sure the generator is on a level surface. To check oil level:

- 1) Turn the oil gauge dipstick(A) Fig.1 counterclockwise, remove it and clean it with a clean cloth.
- 2) Fully reinsert the oil gauge dipstick and pull it out to check the oil level.
- 3) If the oil level is close to the "L" (low mark), refill with SAE 10W30 oil through the dipstick hole until the oil level reaches "H" (high mark) on the dipstick.
- 4) Reposition the oil gauge dipstick and tighten it by turning clockwise.

FUEL LEVEL

WARNING! Make sure there is enough fuel in the fuel tank before operating.

This water pump comes without fuel in the fuel tank and will require clean unleaded gasoline with a minimum of 87 octane. Do not mix oil with gasoline. Fuel tank capacity: 3.6 Litres.

You can check the fuel level by undoing the fuel cap (A) Fig.2 by turning it counterclockwise and making a visual inspection. If it is necessary to add fuel, first make sure the engine is OFF and fill gas tank with gasoline up to maximum fuel level as shown in Fig.3. When refueling, keep in mind all safety precautions and make sure to add enough fuel based on usage.

AIR CLEANER FILTER

The air cleaner filter should be checked to make sure it is clean, especially after prolonged use or storage, the following steps should be done when checking air cleaner filter:

- 1) Remove the wing nut (A) Fig.4 and the air cleaner cover (B) as shown.
- 2) Undo the wing nut (C) Fig.4 and remove the air cleaner filter assembly (D). Remove and wash air filter (E) in kerosene, squeeze kerosene out, soak filter in engine oil and squeeze engine oil out.
- 3) Reinstall air filter onto air filter assembly and secure it with the wing nut. Then reinstall the air filter cover, secure it with the wing nut.

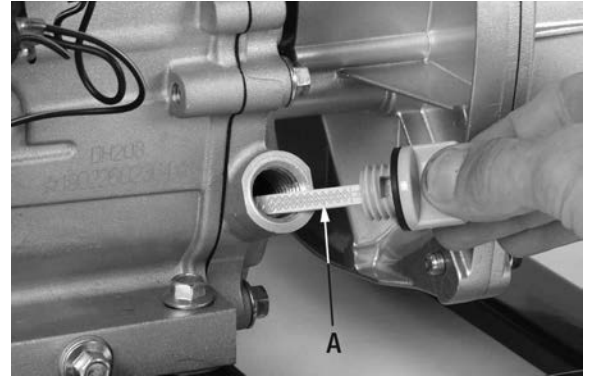

Figure 1



Figure 2

Max. Fuel Level

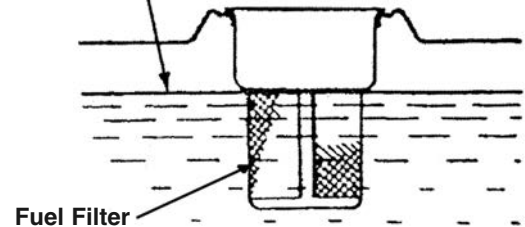

Figure 3



Figure 4

INSPECTION & SET-UP BEFORE STARTING ENGINE

WARNING! To prevent permanent damage to your water pump, you **MUST** assemble all hoses (not supplied), hose adaptors and strainer basket if needed, prime the water pump and have the inlet hose submerged in water before starting water pump engine.

CONNECTING HOSE ADAPTORS TO PUMP INLET AND OUTLET

This water pump comes with 2 hose adaptors and 2 rubber gaskets, these items allow you to connect regular hoses with a 2" diameter without threaded ends (not supplied, see your local hardware store) to the inlet or outlet of the water pump. The following assembly steps apply to both the water pump inlet and outlet:

- 1) Unscrew and remove nut connector (A) Fig.5, place hose adaptor (B) into the nut connector, then press rubber gasket (C) on the inside of the nut connector, against the hose adaptor. Fig.5 shows the assembly of the outlet nut connector.
- 2) Screw the entire assembly onto the outlet thread and tighten securely. Your water pump will look like Fig.6 once both hose adaptors are assembled. Make sure they are both tightened properly to avoid water leaks.

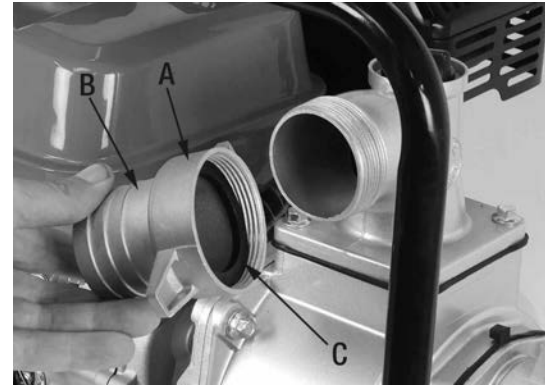

Figure 5

CONNECTING HOSES TO HOSE ADAPTORS

This water pump does not include water hoses and you will need to purchase 2 hoses of the required length having a diameter of 2". It is required to get a reinforced hose with or without 2" NPT to assemble to the inlet (2" NPT hoses do not require hose adaptors, see Fig.7), a non-reinforced hose will collapse on itself from the suction force and prevent water flow, which could cause damage to the engine and water pump machine seal.

- 1) If you purchased a 2" NPT reinforced hose, screw it onto the inlet thread as shown in Fig.7.
- 2) If you purchased a non-thread 2" reinforced hose, attach it to the inlet hose adaptor and fasten hose as shown in Fig.8 and explained in the following steps.



Figure 6

ASSEMBLING & CONNECTING STRAINER BASKET TO INLET HOSE

If this water pump is used to pump water from a river, it is very important to install the strainer basket to the inlet hose to prevent suction of rocks or weeds. Fig.7 shows the pump inlet and hose. Attach strainer basket to the other end of inlet hose.

- 1) Snap the strainer basket (A) Fig.8 and the strainer basket adaptor (B) together as shown.
- 2) Place a wire clamp (C) over the end of the inlet hose (D) (it may be required to cut the 2" NPT off to install the adaptor), then slide both over the strainer basket adaptor.
- 3) With the hose completely positioned over the strainer basket adaptor, position the wire clamp over the ribbed portion of the strainer basket adaptor and tighten wire clamp screw (E) using a screwdriver. Make sure to tighten properly to avoid water leaks.

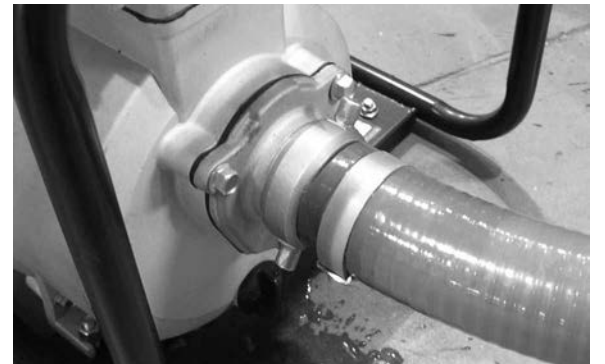

Figure 7

PRIMING THE WATER PUMP

Warning! Never turn the engine on until you have primed the water pump. This means adding water inside the water pump, up close to the rim of the priming cap. Make sure all pre-operation and assembly instructions have been followed before priming water pump.

- 1) Unscrew and remove priming cap (A) Fig.9, fill the water pump with water all the way up close to the priming cap thread.
- 2) Reposition priming cap and tighten.

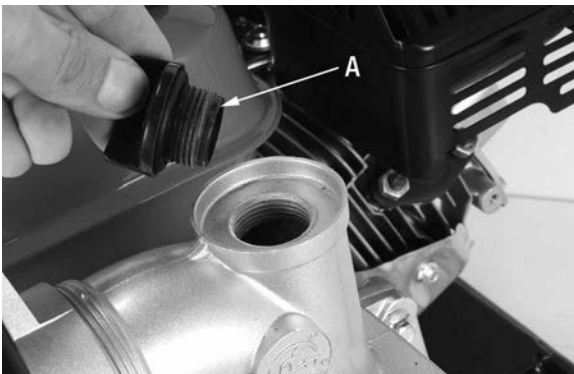

Figure 9

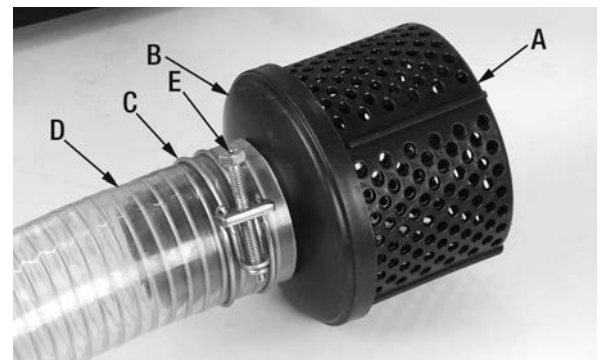

Figure 8

STARTING/STOPPING YOUR WATER PUMP

BEFORE STARTING THIS WATER PUMP, MAKE SURE THE INSPECTION AND SET-UP INSTRUCTIONS ON THE 2 PREVIOUS PAGES HAVE BEEN FOLLOWED OR ELSE YOU RISK DAMAGING YOUR WATER PUMP AND VOIDING WARRANTY.

STARTING YOUR WATER PUMP

Warning! Never run engine indoors or in enclosed, poor ventilated areas, engine exhaust contains carbon monoxide, an odorless and deadly gas!

NOTE: IF ENGINE OIL LEVEL IS TOO LOW, ENGINE WILL NOT START. CHECK OIL LEVEL AND ADD OIL IF NECESSARY.

Turning the water pump engine on:

- 1) Open the fuel shut-off valve lever (A) Fig.10 by moving it completely to the right.
- 2) Turn the On/Off switch (A) Fig.11 to the "On" position.
- 3) Close the choke control lever (B) Fig.10 (located on top of the fuel shut-off lever) by moving it completely to the left "Off" position.
NOTE: No choke is required on warm engines. Make sure choke lever is moved all the way to the right "On" position for warm engine starts.
- 4) Move the throttle lever (C) Fig.10 a little from the left side towards to the right side.
- 5) Pull the recoil starter handle (D) Fig.10 until resistance is felt, then pull it out with a rapid full arm stroke. Let the starter rope rewind slowly, repeat if necessary until the engine starts.
- 6) Once the engine starts, gradually move the choke lever all the way to the right "On" position. It is recommended to warm up the engine for 3 minutes upon each initial start-up to allow engine to stabilize. After 3 minutes, move the throttle lever all the way to the left position for maximum engine RPM and maximum pumping force.
- 7) If you notice that the water pump is not pumping water, this is probably because there is air trapped in the water pump. Loosen the priming cap (A) Fig.9 to release trapped air and retighten cap once the correct flow of water is obtained.

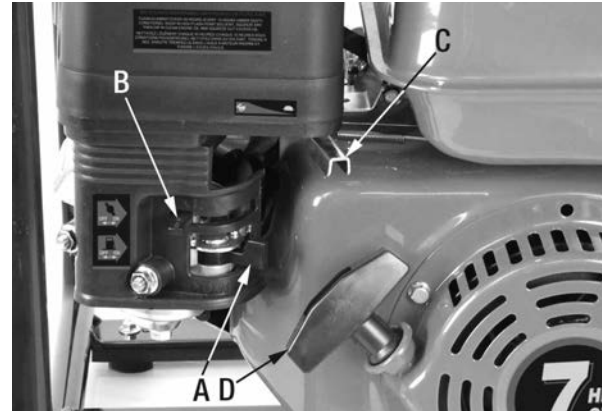

Figure 10



Figure 11

Stopping the water pump engine:

- 1) Move the throttle lever completely to the right "Off" position.
- 2) Turn the engine power "ON" switch to the "OFF" position.
- 3) Close the fuel shut-off valve lever by moving it completely to the left.

In case of emergency, turn the switch to the "Off" position to stop the engine.

MAINTENANCE & STORAGE

Engine Oil Replacement (Oil capacity: 0.6 Liters)

Engine oil should be replaced after the first 20 hours of operation or after the first month of use, it should be replaced every 100 hours or 6 months after. To replace engine oil:

- 1) Unscrew and remove the oil gauge dipstick (A) Fig.12.
- 2) Place an oil pan underneath drain hex. bolt (B), remove hex. bolt (B) and drain oil.
- 3) Once all the oil has completely drained, retighten the hex. bolt (B).

Recommended Engine Oil

It is recommended to use SAE10W30 4-stroke gasoline engine oil. For cold weather (below -15°C) use SAE 5W30.

- 4) Fill with clean engine oil through the oil gauge dipstick hole, fully reinsert the oil gauge dipstick and pull it out to check the oil level.
- 5) If the oil level is close to the "L" (low mark), refill with SAE 10W30 oil through the dipstick hole until the oil level reaches "H" (high mark) on the dipstick.
- 6) Reposition the oil gauge dipstick and tighten it by turning clockwise.

Inspecting, Replacing or Cleaning Spark Plug

The spark plug should be checked every 100 hours of operation or every 6 months. To replace or clean spark plug:

- 1) Dismantle the spark plug cap (A) Fig.13 by pulling it off the spark plug (B). Using the supplied spark plug wrench, undo the spark plug by turning counterclockwise.
- 2) Check to see if there is carbon sediment build-up, if so just remove it. If the carbon sediment is excessive, replace the spark plug.
- 3) Measure the electrodes clearance. See Fig.14. The spark plug electrode clearance should be between 0.7-0.8mm. If the clearance exceeds 0.8mm, replace the spark plug.
- 4) Reinstall spark plug in the reverse order.

Water pump Storage

If you plan on storing your water pump for an extended period of time, the following steps should be followed:

- 1) Add fuel stabilizer to fuel tank to minimize the formation of fuel gum deposits during storage. Run engine at least 5 minutes after adding stabilizer to allow it to enter the fuel system.
- 2) Drain all the water from the pump housing before storing, this can be done by undoing the drain cap at the bottom of the pump housing.
- 3) Remove the spark plug, add about 2-3 cc of engine oil into the cylinder and reinstall spark plug. Pull the recoil starter handle until resistance is felt. Now both inlet and outlet valves are closed to prevent the engine chamber from rusting.

NOTE: If a fuel stabilizer is not used, all gasoline must be drained from the tank and carburetor to prevent gum deposits from forming on these parts and causing possible malfunction of the engine.

- 4) Turn fuel shut-off valve lever to the right "On" position and remove the tank cap.
- 5) Remove drain hex. bolt (B) Fig.15 from the carburetor (A) and drain all fuel inside the tank.
- 6) Reposition the carburetor drain hex. bolt once the fuel is completely drained.
- 7) Drain engine oil from engine as described in "Engine Oil Replacement".
- 8) Pull the recoil starter handle gently until resistance is felt.

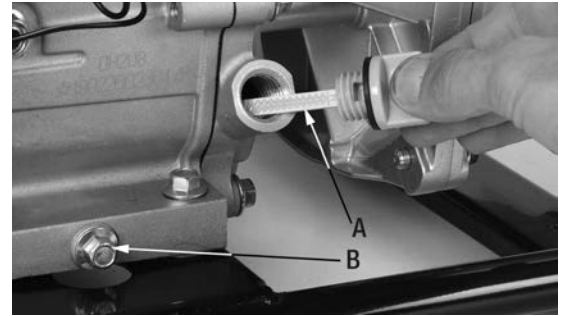

Figure 12

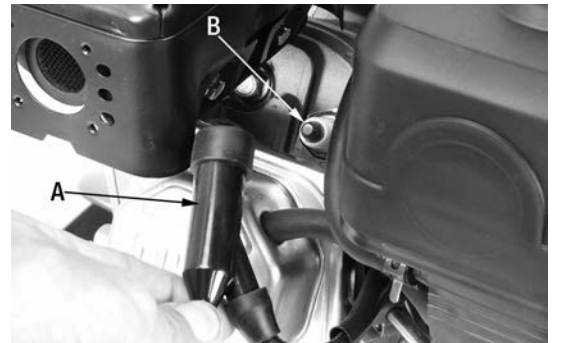

Figure 13

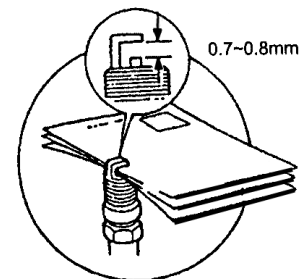

Figure 14

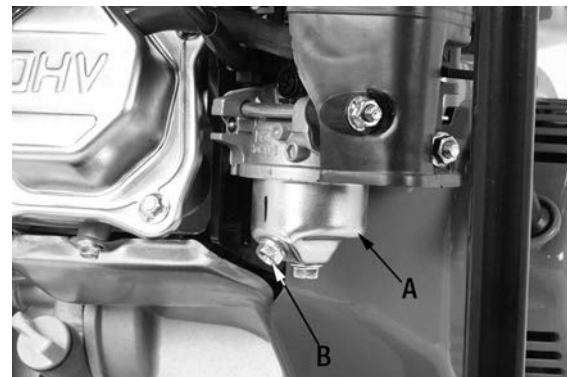

Figure 15

INSPECTION & TROUBLESHOOTING

Daily and Regular Inspection

WARNING! Daily and regular inspection is important to ensure safe, proper and long-term operation of the engine. Refer to the inspection table when conducting inspections and maintenance and follow the recommended time intervals.

* Only after the first time

Noted: Item marked with a | require advanced skill and tools, and must only be done by a qualified technician.

If the engine still does not start in spite of the mentioned inspections, have it serviced by an authorized service center.

Item \ Time	Every Operation	Every 20 hours	Every 50 hours	Every 100 hours
Inspection and tightening of bolt and nut at each place	m			
Engine oil level check and supply	m			
Change of engine oil		m*	m	
Check for fuel and oil leaks	m			
Check and cleaning the air filter	m			
Check and cleaning of spark plug			m	
Check and cleaning of fuel strainer			m	
Remove of carbon in combustion chamber				
Check and adjustment of valve clearance				
Replace the fuel lines	2 years (or when necessary)			

Water Pump Troubleshooting Guide

Malfunction	Cause	Remedy
The pump is incapable of pumping	Not enough water	Pour water into the pump
	Inlet pipe leakage	Check inlet hose and hose connector Change hose or tighten the clamp screw
	Speed of the engine is too low	Increase speed with throttle lever
	The filter net is obstructed	Check it and clean it
	The pump has exceed its capacity	Check the position of water pump
	The seal was abraded and there is an air leak	Change the machinery seal set

TROUBLESHOOTING

Malfunction	Cause	Remedy
The water is not flowing enough	The filter net, hoseline or impeller is choked	Clean up the obstruction
	Speed is too low	Increase the speed
	Impeller seal is seriously worn	Adjust the gap or change impeller and machinery seal
	Inlet hose leakage	Check inlet hose and hose connector or tighten clamp screw
	The impeller is damaged and there is serious leakage	Install a new impeller
Power consumption of the pump is too large	Total head is too high	Check the reason and adjust it
	There is air in the pump or inlet	Loosen priming cap to release trapped air
	There is an air leak in the seal	Check the hose or change the machinery seal
	Speed of the engine is not stable	Adjust the speed of the engine
	There is a rub between the impeller and flow guidance	Listen as to whether the impeller is touching the case and adjust
	The impeller is obstructed by foreign matter	Check and clean up
Sudden stop of flow	The connector of the inlet hose is loose and leaking	Check the inlet hose and fix it
	Suction head is too high and causing cavations	Check the suction head and lower the position of the pump
Causes vibration or noise	Suction head is too high and causing cavations	Check the suction head and lower the position of the pump
	Output of water is too large	Decrease the speed of engine
	Inlet hose is obstructed by foreign matter so the resistance is too large	Check the inlet hose and strainer basket and clean them
	Rotary part is loose	Check the inlet hose and strainer basket and clean them
	Pump is not a level, stable surface	Stop the machine and change position
	There is air in the pump or inlet	Loosen priming cap to release air
	The impeller is damaged	Stop the machine and replace the impeller with a new one

Malfunction	Cause	Remedy
Engine will not start	<ol style="list-style-type: none"> 1. Low on fuel or oil. 2. Ignition switch in "Off" position. 3. Faulty spark plug. 4. Choke in wrong position. 5. Fuel shut-off valve is closed. 6. Spark plug wire loose. 	<ol style="list-style-type: none"> 1. Add fuel or oil. 2. Turn to "ON" position. 3. Replace spark plug. 4. Adjust choke accordingly. 5. Open fuel shut-off valve. 6. Attach wire to spark plug.

PARTS DIAGRAM & PARTS LISTS

Refer to the Parts section of the King Canada web site for the most updated parts diagram and parts list.